

Portable Induction Heater TIH 030m

Small bearing heater with high heating capacity of up to 40 kg bearing

The new SKF small induction heater TIH 030m combines high heating capacity with portability. The compact lightweight design makes the TIH 030m portable. Placing the induction coil outside the heater's housing allows the heating of bearings weighing up to 40 kg (88 lb). The heater is equipped with thermal overheating protection to reduce the risk of damage to the induction coil and the electronics. In addition to temperature mode, the TIH 030m is equipped with a time mode for heating components other than bearings. The heater is supplied standard with three yokes and is available in two executions: 230V/50-60Hz and 100-110V/50-60Hz.

SKF m₂₀ concept

"m₂₀" represents the weight (kg) of the heaviest SRB 231 bearing which can be heated from 20 to 110 °C (68 to 230 °F) in 20 minutes. This defines the heater's power output instead of its power consumption.

- Compact lightweight design; just 20,9 kg (46.0 lb) facilitating portability
- 2-step power setting and smaller yokes allow heating smaller bearings safely and at lower power consumption
- Capable of heating a 28 kg (61.7 lb) bearing in just 20 minutes
- Temperature mode pre-set at 110 °C (230 °F) to help prevent bearing over-heating
- Automatic demagnetisation
- 3 years warranty



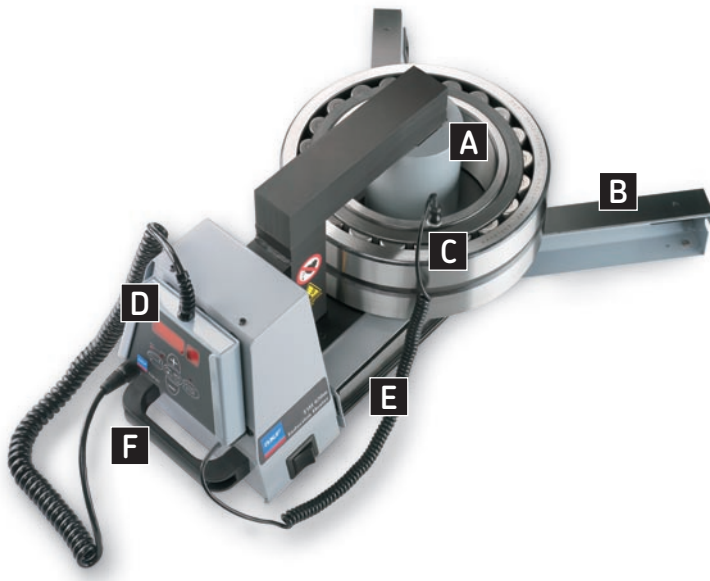

- A** Induction coil outside the heater's housing allows shorter heating time and lower energy consumption
- B** Foldable bearing support arms facilitate the heating of larger diameter bearings
- C** Magnetic temperature probe helps prevent bearing overheating
- D** Easy-to-use control panel and LCD display integrated in a remote control
- E** Internal storage for all 3 yokes reduces the risk of yoke damage or loss
- F** Integrated carrying handle facilitates portability

Technical data

Designation

TIH 030M/230V
TIH 030M/110V

SKF m ₂₀ performance	28 kg (61.7 lb)
Voltage, V/Hz	230V/50-60Hz or 100-110V/50-60Hz
Work piece:	
- Maximum weight	40 kg (88 lb)
- Maximum bore diameter	20 - 300 mm (0.8 - 11.8 in)
Temperature control:	
- Range	0 - 250 °C (32 - 482 °F)
- Magnetic probe	Yes, K-type
- Accuracy (electronics)	± 2 °C (± 3.6 °F)
Time control:	
- Range	0 - 60 minutes
- Accuracy	± 0,01 sec.
Maximum temperature (approx.)	400 °C (750 °F)
Thermometer mode	Yes
Bearing mode	Yes
Power setting	2-step; 50% or 100%
Demagnetisation according to SKF norms (automatic)	Yes (<2 A/cm)
Can heat sealed bearings	Yes
Can heat pre-greased bearings	Yes
Error guiding codes	Yes
Thermal overload protection	Yes
Control panel	Control panel and LED display integrated in remote controle
Operating area (w x h)	100 x 135 mm (3.9 x 5.3 in)
Coil diameter	95 mm (3.7 in)
Dimensions (w x d x h)	450 x 195 x 210 mm (17.7 x 7.6 x 8.2 in)
Total weight, including yokes	20,9 kg (46.0 lb)
Maximum power consumption	2,0 kVA
Standard yokes	45 x 45 x 215 mm (1.7 x 1.7 x 8.4 in), for heating bearings with bore diameter of 65 mm (2.6 in) and larger. 28 x 28 x 215 mm (1.1 x 1.1 x 8.4 in), for heating bearings with bore diameter of 40 mm (1.6 in) and larger. 14 x 14 x 215 mm (0.5 x 0.5 x 8.4 in), for heating bearings with bore diameter of 20 mm (0.8 in) and larger.
Core cross section	45 x 45 mm (1.7 x 1.7 in)
Bearing support arms	Yes, foldable
Yoke storage	Yes, internal integrated in foldable bearing support arms
Cooling fan	No
Swivel arm	No
Housing material	Steel and glass filled polyamide
Warranty period	3 years



www.mapro.skf.com
www.skf.com/mount

SKF Maintenance Products

© Copyright SKF 2004/11

In line with our policy of continuous development of our products we reserve the right to alter any part of the above specification without prior notice.

Although care has been taken to ensure the accuracy of this publication, SKF does not assume any liability for errors or omissions.

How to contact your authorised distributor

Distribution Centres

Rotherham CDC

T 0845 602 9946

F 01709 789 988

E sales@acorn-ind.co.uk

W www.acorn-ind.co.uk

Midlands RDC

T 0121 521 5999

F 0121 521 5888

E midlands@acorn-ind.co.uk

W www.acorn-ind.co.uk/midlands

North East RDC

T 0191 417 8899

F 0191 419 0001

E northeast@acorn-ind.co.uk

W www.acorn-ind.co.uk/northeast

South West RDC

T 01179 820 414

F 01179 823 222

E southwest@acorn-ind.co.uk

W www.acorn-ind.co.uk/southwest

Regional Branches

North West Branch

T 0845 602 3568

F 01229 833 510

E northwest@acorn-ind.co.uk

W www.acorn-ind.co.uk/northwest

Scotland Branch

T 01506 476 199

F 01506 462 655

E scotland@acorn-ind.co.uk

W www.acorn-ind.co.uk/scotland

Divisions

Export Division

T +44 1709 789 933

F +44 1709 789 966

E export@acorn-ind.co.uk

W www.acorn-ind.co.uk/export

Linear Division

T 01709 789 949

E linear@acorn-ind.co.uk

W www.acorn-ind.co.uk/linear