

P5 Ball Screws

- Ball Screws According to ISO 3408 (DIN 69051)
- Preloaded or without Clearance



How to contact your authorised distributor

Distribution Centres

Rotherham CDC

T 0845 602 9946

F 01709 789 988

E sales@acorn-ind.co.uk

W www.acorn-ind.co.uk

Midlands RDC

T 0121 521 5999

F 0121 521 5888

E midlands@acorn-ind.co.uk

W www.acorn-ind.co.uk/midlands

North East RDC

T 0191 417 8899

F 0191 419 0001

E northeast@acorn-ind.co.uk

W www.acorn-ind.co.uk/northeast

South West RDC

T 01179 820 414

F 01179 823 222

E southwest@acorn-ind.co.uk

W www.acorn-ind.co.uk/southwest

Regional Branches

North West Branch

T 0845 602 3568

F 01229 833 510

E northwest@acorn-ind.co.uk

W www.acorn-ind.co.uk/northwest

Scotland Branch

T 01506 476 199

F 01506 462 655

E scotland@acorn-ind.co.uk

W www.acorn-ind.co.uk/scotland

Divisions

Export Division

T +44 1709 789 933

F +44 1709 789 966

E export@acorn-ind.co.uk

W www.acorn-ind.co.uk/export

Linear Division

T 01709 789 949

E linear@acorn-ind.co.uk

W www.acorn-ind.co.uk/linear

THK P5 Ball Screws

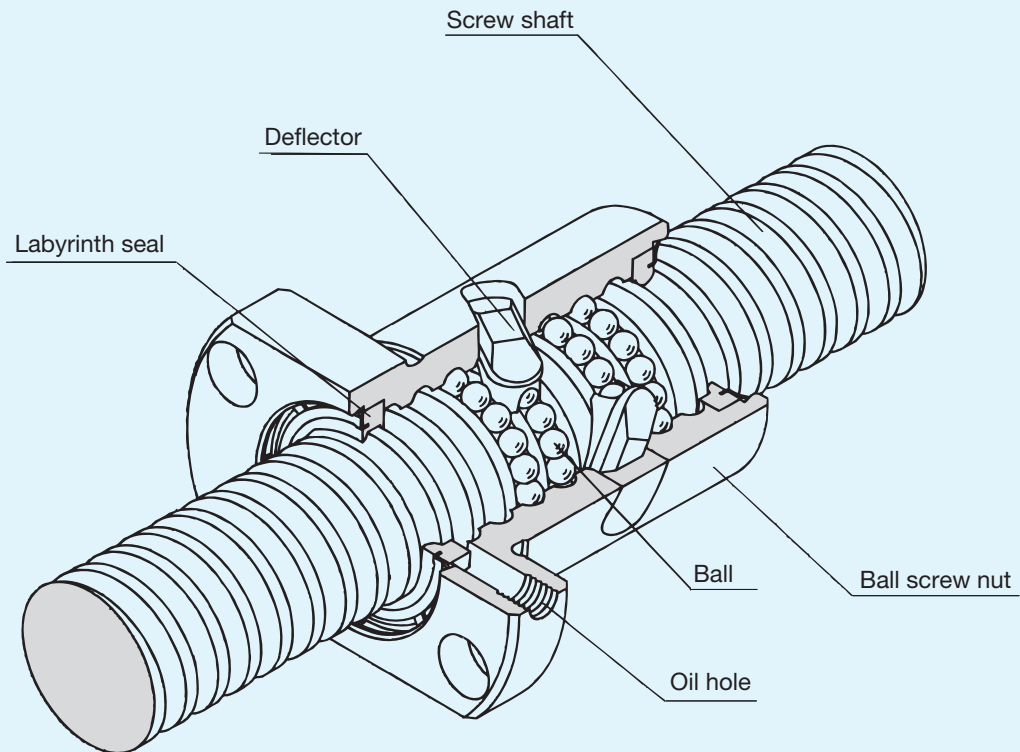

Fig. 1 Structure of a single nut with deflector

● P5 Ball Screws

Ground ball screws are best suited for applications, where high axial rigidity is required. P5 Ball Screws are a cost-effective alternative to ground ball screws.

These products match the accuracy grades of the standard ISO 3408 (DIN 69051).

Standard		ISO/DIN
Accuracy grade		P5
Preload	Pitch offset Type EPB	0.05 Ca
	Ball selection Type EBB	Without clearance

● Support Units and Screw Shafts with Finished Ends Available

THK P5 Ball Screws can be delivered with support units and the appropriate shaft ends.

Product Overview

P5 Ball Screw EPB/EBB (Form B)

Single nut
EBB: without clearance
EPB: preloaded



Pages 8-11

Support Units BK/BF & FK/FF



Pages 12-15

Screw Shaft Selection

Available Diameter/Lead Combinations

The tables below indicate the standard combinations of the screw shafts and leads.

If a diameter and lead combination other than those specified in the table is required, please contact **THK**.

Table 1 EB/EP-Series

Unit: mm

Screw shaft diameter	Lead	
	5	10
16	●	—
20	●	—
25	●	●
32	●	●
40	—	●
50	—	●

Limitations of Screw Shaft Lengths

Table 2 presents the maximum screw shaft lengths by the screw shaft diameter.

If the requested shaft length exceeds the range specified in the table below, please contact **THK**.

Table 2
Limitations of screw shaft length
by screw shaft diameter

Unit: mm

Screw shaft diameter	Max. screw shaft length	
	GT	G0
16	1500	1500
20	2000	2000
25	2000	2000
32	3000	2000
40	3000	2000
50	3000	2000

DN Value

The permissible rotational speed of the ball screw should be determined based on the critical speed and DN value.

The permissible rotational speed determined based on the DN value can be calculated using the following equation.

- P5 Ball Screw with normal lead

$$N = \frac{70,000}{d_p}$$

N : permissible rotational speed determined based on the DN value (min⁻¹)

d_p : ball center-to-center diameter (presented in the dimension table P. 8 und 10) (mm)

For operating rotational speeds greater than N, high-speed ball screws are available. If you require these models, please contact **THK**.

Preload and Rigidity

Preload

The preload eliminates the axial clearance of the ball screw and improves the rigidity. Furthermore, the preload ensures positioning accuracy.

Preload methods

(A) Preload by pitch shift method: The pitch is shifted at the central part of the nut to create the requested preload.

(B) Without clearance by ball selection: The nut is filled with balls in a certain diameter to eliminate the clearance.

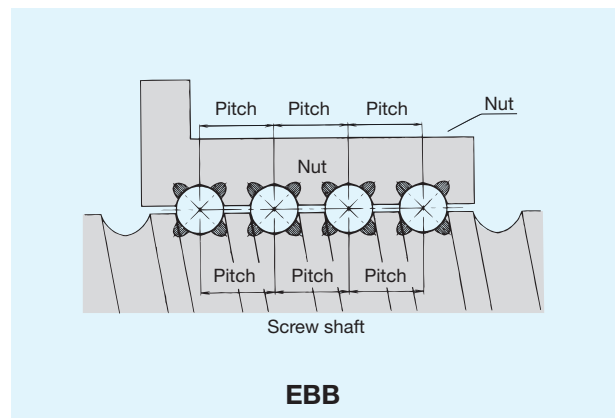
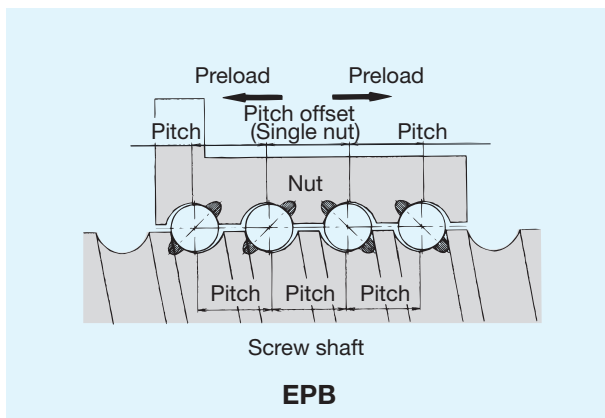

Accuracy Grades

Travel Variation and Travel Deviation

The accuracy grades of the P5 Ball Screws are related to ISO 3408 (DIN 69051).

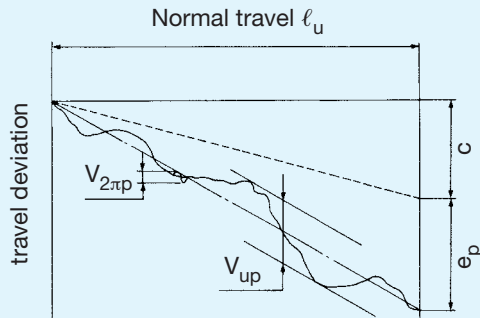

Figure 2 Permissible travel deviation and travel variation in relation to the nominal travel

Definitions according to DIN/ISO Standard:

- e_p : Tolerance on specified travel. The difference between the maximum and minimum values of the permissible actual mean travel.
- V_{up} : Permissible travel variation in relation to the nominal travel l_u .
- $V_{2\pi p}$: Permissible travel variation in relation to one rotation 2π rad.
- V_{300p} : Permissible travel deviation over 300 mm travel.
- c : Travel compensation. The difference between the specified travel and nominal travel within the useful travel (Standard: $c = 0$).

Table 3 Tolerance on specified travel $\pm e_p$ and permissible travel variation V_{up} in relation to the nominal travel l_u for positioning ball screws.

Unit: μm

Standard		ISO/DIN P5 ¹⁾	
over	to (incl.)	e_p	V_{up}
—	315	23	23
315	400	25	25
400	500	27	26
500	630	32	29
630	800	36	31
800	1000	40	34
1000	1250	47	39
1250	1600	55	44
1600	2000	65	51
2000	2500	78	59
2500	3150	96	69
3150	4000	115	82

Table 4 Permissible travel variation in relation to one rotation $V_{2\pi p}$ and permissible travel variation over 300 mm travel V_{300p} for positioning ball screws.

Unit: μm

Standard	ISO/DIN P5 ¹⁾
V_{300p}	23
$V_{2\pi p}$	8

¹⁾ P5 = Positioning ball screws of the accuracy grade 5 according to ISO 3408 (DIN 69051)

Accuracy of the Mounting Section

The mounting surface accuracy of the P5 Ball Screws according to DIN/ISO Standard.

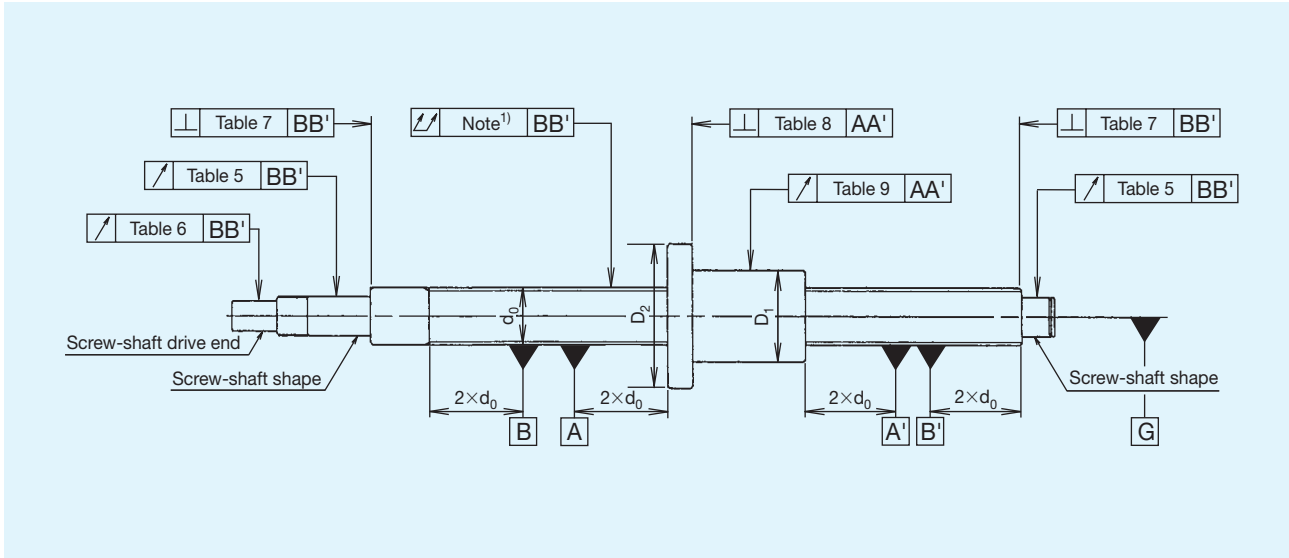

1) For the overall run-out of the screw shaft axis in the radial direction, refer to ISO 3408 (DIN 69051), part 3.

Table 5 Radial run-out of the drive shaft in respect to BB' Unit: μm

Nominal diameter d_0 (mm)		ℓ (mm)	Radial run-out P5
Over	Up to (incl.)		
6	20	80	20
20	50	125	25

Notes: For more detailed information and test instructions see ISO 3408 (DIN 69051), part 3.

Table 6 Radial run-out of the drive shaft diameter in respect to the bearing diameter. Ball screw is supported at the points BB'

Unit: μm

Nominal diameter d_0 (mm)		ℓ (mm)	Coaxial deviation P5
Over	Up to (incl.)		
6	20	80	8
20	50	125	10

Notes: For more detailed information and test instructions see ISO 3408 (DIN 69051), part 3.

Table 7 Axial run-out of the bearing journal abutment face in respect to BB'

Unit: μm

Nominal diameter d_0 (mm)		Axial run-out P5
Over	Up to (incl.)	
6	63	5

Notes: For more detailed information and test instructions see ISO 3408 (DIN 69051), part 3.

Table 8 Perpendicularity of the flange mounting surface in respect to AA'

Unit: μm

Flange diameter D_2 [mm]		Perpendicularity P5
Over	Up to (incl.)	
16	32	16
32	63	20
63	125	25

Notes: For more detailed information and test instructions see ISO 3408 (DIN 69051), part 3.

Table 9 Radial run-out of the outer diameter of the nut in respect to AA'

Unit: μm

Outer diameter D_1 [mm]		Run-out P5
Over	Up to (incl.)	
16	32	16
32	63	20
63	125	25

Notes: For more detailed information and test instructions see ISO 3408 (DIN 69051), part 3.

Table 10 Measurement of radial run-out of the ball screw shaft outer diameter for ascertaining straightness related to BB' per length ℓ_5

Unit: μm

Nominal diameter d_0 [mm]		Reference length ℓ_5 [mm]	Run-out P5
Over	Up to (incl.)		
12	25	160	32
25	50	315	32

Notes: For more detailed information and test instructions see ISO 3408 (DIN 69051), part 3.

Table 11 Maximum radial run-out of the ball screw shaft diameter valid for $\ell_1 \geq 4\ell_5$

Unit: μm

$\frac{\ell_1}{d_0}$		Run-out (max.) P5
Over	Up to (incl.)	
—	40	64
40	60	96

ℓ_1 = Effective screw shaft length [mm]

d_0 = Screw shaft outer diameter [mm]

ℓ_5 = Reference length [mm]

Notes: For more detailed information and test instructions see ISO 3408 (DIN 69051), part 3.

P5 Ball Screw EBB

- Single nut according to ISO 3408 (DIN 69051) with flange form B
- Without clearance by ball selection

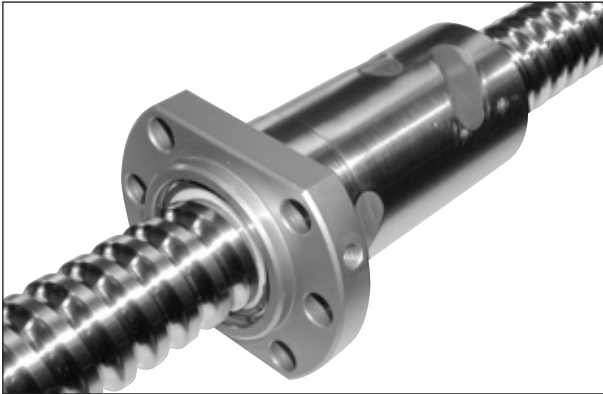

Model No.	Screw shaft diameter d	Lead ℓ	Ball center-to-center diameter d _p	Thread minor diameter d ₃	Number of loaded rows × circuits	Basic load rating		Rigidity ¹⁾ K [N/μm]
						C _a [kN]	C _{0a} [kN]	
EBB1605-4RR	16	5	16.75	13.1	4×1	9.5	17.4	210
EBB2005-3RR	20	5	20.75	17.1	3×1	8.5	17.3	200
EBB2505-3RR	25	5	25.75	22.1	3×1	9.7	22.6	250
EBB2510-3RR	25	10	26	21.6	3×1	12.7	27.0	250
EBB2510-4RR	25	10	26	21.6	4×1	16.7	37.6	330
EBB3205-3RR	32	5	32.75	29.2	3×1	11.1	30.2	300
EBB3205-4RR	32	5	32.75	29.2	4×1	14.2	40.3	400
EBB3205-6RR	32	5	32.75	29.2	6×1	20.1	60.4	600
EBB3210-3RR	32	10	33.75	26.4	3×1	25.7	52.2	300
EBB3210-4RR	32	10	33.75	26.4	4×1	33.0	69.7	390
EBB4010-3RR	40	10	41.75	34.4	3×1	29.8	69.3	380
EBB4010-4RR	40	10	41.75	34.4	4×1	38.1	92.4	500
EBB5010-4RR	50	10	51.75	44.4	4×1	43.4	120.5	610

¹⁾ The rigidity values in the table represent spring constants obtained from the load and the elastic displacement when providing an axial load 30% of the basic dynamic load rating (C_a). These values do not include the rigidity of the components related to mounting the ball screw nut. Therefore, it is normally appropriate to regard roughly 80% of the value in the table as the actual value. If the axial load (F_a) is not 0.3 C_a, the rigidity value (K_N) is obtained from the following equation.

$$K_N = K \cdot \left(\frac{F_a}{0,3 \cdot C_a} \right)^{\frac{1}{3}}$$

K : Rigidity value in the dimensional table.
F_a : Axial load

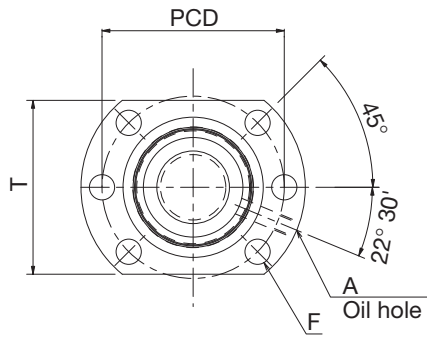

Drilling template 1

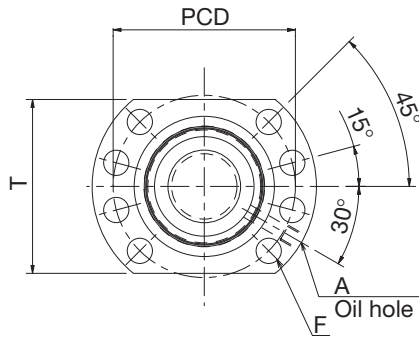

Drilling template 2

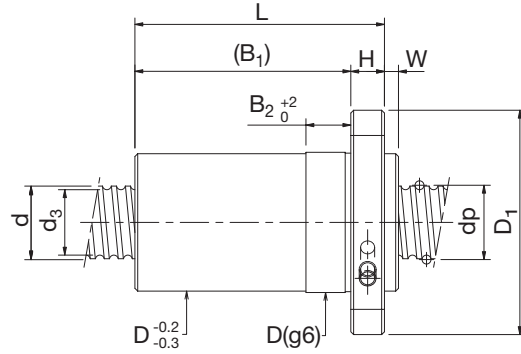

Unit: mm

Nut dimensions											Oil hole A	Screw shaft inertial moment per mm [kg · cm ² /mm]
Outer diameter D	Flange diameter D ₁	Overall length L	H	B ₁	B ₂	W	T	PCD	F	Drilling template		
28	48	50	10	40	10	5	40	38	5.5	1	M6×1	5.05×10 ⁻⁴
36	58	45	10	35	10	5	44	47	6.6	1	M6×1	1.23×10 ⁻³
40	62	45	10	35	10	5	48	51	6.6	1	M6×1	3.01×10 ⁻³
40	62	75	10	65	16	5	48	51	6.6	1	M6×1	3.01×10 ⁻³
40	62	80	10	70	16	5	48	51	6.6	1	M6×1	3.01×10 ⁻³
50	80	47	12	35	10	5	62	65	9	1	M6×1	8.08×10 ⁻³
50	80	52	12	40	10	5	62	65	9	1	M6×1	8.08×10 ⁻³
50	80	62	12	50	10	5	62	65	9	1	M6×1	8.08×10 ⁻³
50	80	77	12	65	16	5	62	65	9	1	M6×1	8.08×10 ⁻³
50	80	89	12	77	16	5	62	65	9	1	M6×1	8.08×10 ⁻³
63	93	79	14	65	16	5	70	78	9	2	M8×1	1.97×10 ⁻²
63	93	89	14	75	16	5	70	78	9	2	M8×1	1.97×10 ⁻²
75	110	91	16	75	16	5	85	93	11	2	M8×1	4.82×10 ⁻²

Model Number Coding

EBB 32 05 - 4 RR GT + 1200L Cp5R

(1) (2) (3) (4) (5) (6) (7) (8)

- (1) Nut
- (2) Screw shaft outer diameter (mm)
- (3) Lead (mm)
- (4) Number of circuits (rows × turns)

- (5) Seals (RR: labyrinth seals attached to both sides)
- (6) Symbol for preload
GT = 0 to 0.005 mm axial clearance;
G0 = without clearance
- (7) Screw shaft total length (mm)
- (8) Accuracy

P5 Ball Screw EPB

- Single nut according to ISO 3408 (DIN 69051) with flange form B
- Preload by pitch offset



Model No.	Screw shaft diameter d	Lead ℓ	Ball center-to-center diameter d_p	Thread minor diameter d_3	Number of loaded rows \times circuits	Basic load rating		Rigidity ¹⁾ K [N/ μ m]
						C_a [kN]	C_{0a} [kN]	
EPB1605-6RR	16	5	16.75	13.1	3 \times 1	7.4	13	320
EPB2005-6RR	20	5	20.75	17.1	3 \times 1	8.5	17.3	310
EPB2505-6RR	25	5	25.75	22.1	3 \times 1	9.7	22.6	490
EPB2510-4RR	25	10	26	21.6	2 \times 1	9.0	18.0	330
EPB3205-6RR	32	5	32.75	29.2	3 \times 1	11.1	30.2	620
EPB3205-8RR	32	5	32.75	29.2	4 \times 1	14.2	40.3	810
EPB3210-6RR	32	10	33.75	26.4	3 \times 1	25.7	52.2	600
EPB4010-6RR	40	10	41.75	34.4	3 \times 1	29.8	69.3	750
EPB4010-8RR	40	10	41.75	34.4	4 \times 1	38.1	92.4	1000
EPB5010-8RR	50	10	51.75	44.4	4 \times 1	43.4	120.5	1230

¹⁾ The rigidity values in this table indicate spring constants obtained from the load and elastic displacement under a preload of 10% of the basic dynamic load rating C_a , and an axial load F_a that is three times that of the preload F_{a0} . As these values do not take into account the rigidity of the parts involved in the nut installation, take 80% of the values given in this table as a general guideline.

If the preload F_{a0} differs from 0.1 C_a , the rigidity K_N can be calculated using the following equation:

$$K_N = K \cdot \left(\frac{F_{a0}}{0.1 C_a} \right)^{\frac{1}{3}} \cdot 0.8$$

If the ball screw is not preloaded, please consult **THK** for the rigidity value.

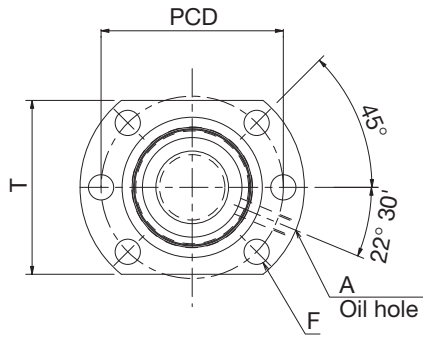

Drilling template 1

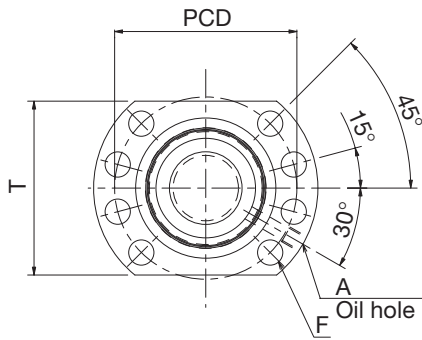

Drilling template 2

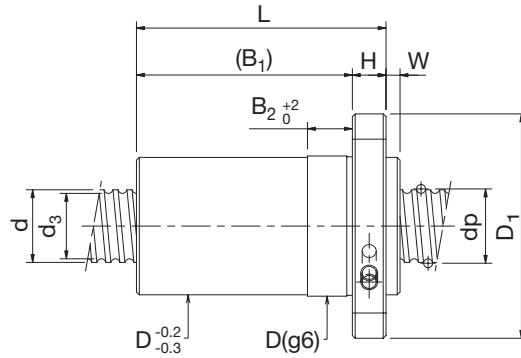

Unit: mm

Nut dimensions											Drilling template	Oil hole	Screw shaft inertial moment per mm [kg · cm ² /mm]
Outer diameter	Flange diameter	Overall length	H	B ₁	B ₂	W	T	PCD	F	A			
28	48	60	10	50	10	5	40	38	5.5	1	M6×1	5.05×10 ⁻⁴	
36	58	61	10	51	10	5	44	47	6.6	1	M6×1	1.23×10 ⁻³	
40	62	61	10	51	10	5	48	51	6.6	1	M6×1	3.01×10 ⁻³	
40	62	80	10	70	16	5	48	51	6.6	1	M6×1	3.01×10 ⁻³	
50	80	62	12	50	10	5	62	65	9	1	M6×1	8.08×10 ⁻³	
50	80	73	12	61	10	5	62	65	9	1	M6×1	8.08×10 ⁻³	
50	80	107	12	95	10	5	62	65	9	1	M6×1	8.08×10 ⁻³	
63	93	109	14	95	16	5	70	78	9	2	M8×1	1.97×10 ⁻²	
63	93	133	14	119	16	5	70	78	9	2	M8×1	1.97×10 ⁻²	
75	110	135	16	119	16	5	85	93	11	2	M8×1	4.82×10 ⁻²	

Model Number Coding

EPB 32 05 – 6 RR G0 + 1200L Cp5R

(1) (2) (3) (4) (5) (6) (7) (8)

- (1) Nut
- (2) Screw shaft outer diameter (mm)
- (3) Lead (mm)
- (4) Number of circuits (rows × turns)
- (5) Seals (RR: labyrinth seals attached to both sides)
- (6) Symbol for preload
G0 = preload
- (7) Screw shaft total length (mm)
- (8) Accuracy

Ball Screw Support Units Type BK/BF (Base Mounting Type)

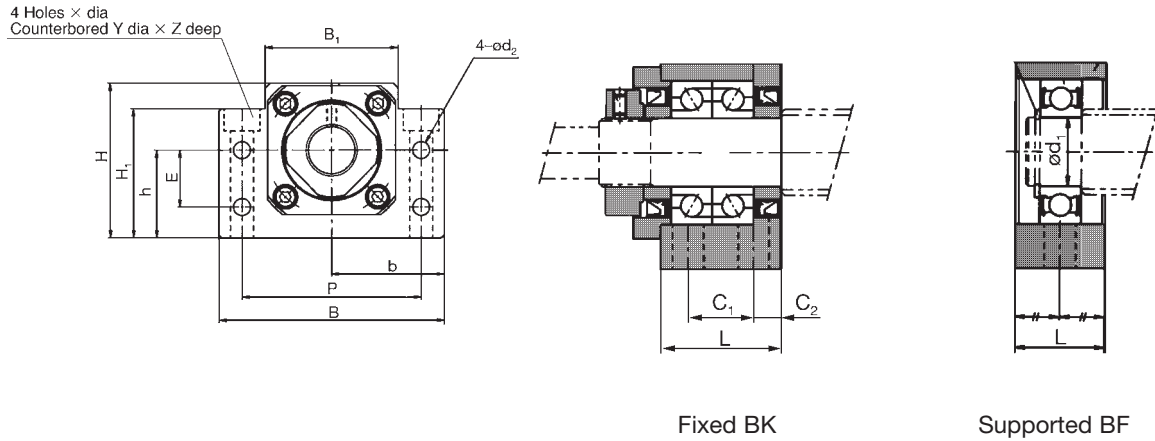

Unit: mm

Shaft diameter d	Body sizes				Datum ±0.02 ±0.02		Fixing holes						Fixed bearing unit (BK)						Supported bearing unit (BF)					
	B	H	B ₁	H ₁	b	h	E	P	d ₂	X	Y	Z	L	Dyn. load rat. C _a [kN]	Permissible Load [kN]	Rigi- dity [N/μm]	C ₁	C ₂	d ₁	Dyn. load rating C[kN]	Basic load rating C ₀ [kN]	L		
16	60	43	35	32,5	30	25	18	46	5.5	6.6	11	1.5	BK12	25	6.66	3.25	88	13	6	BF12	10	4.55	1.96	20
20	70	48	40	38	35	28	18	54	5.5	6.6	11	6.5	BK15	27	7.6	4	100	15	6	BF15	15	5.6	2.84	20
25	86	64	50	55	43	39	28	68	6.6	9	14	8.5	BK17	35	13.7	5.85	125	19	8	BF17	17	9.6	4.6	23
32	88	60	52	50	44	34	22	70	6.6	9	14	8.5	BK20	35	12.7	7.55	140	19	8	BF20	20	9.4	5.05	26
40	128	89	76	78	64	51	33	102	11	14	20	13	BK30	45	28	16.3	195	23	11	BF30	30	19.5	11.3	32
50	160	110	100	90	80	60	37	130	14	18	26	17.5	BK40	61	44.1	27.1	270	33	14	BF40	40	29.1	17.8	37

Note: For BK units specify J1, J2 or J3 machining. For BF units specify K machining.

Example: **EBB3205 - 4RRGT + 1200LCp5R - J2K¹⁾**

End machining for supported BF 20

End machining for fixed BK 20

- ¹⁾ End machining for precision ball screw:
 Type J2: Fixed bearing unit for BK20
 Type K : Supported bearing unit for BF20

End Machining for BK/BF

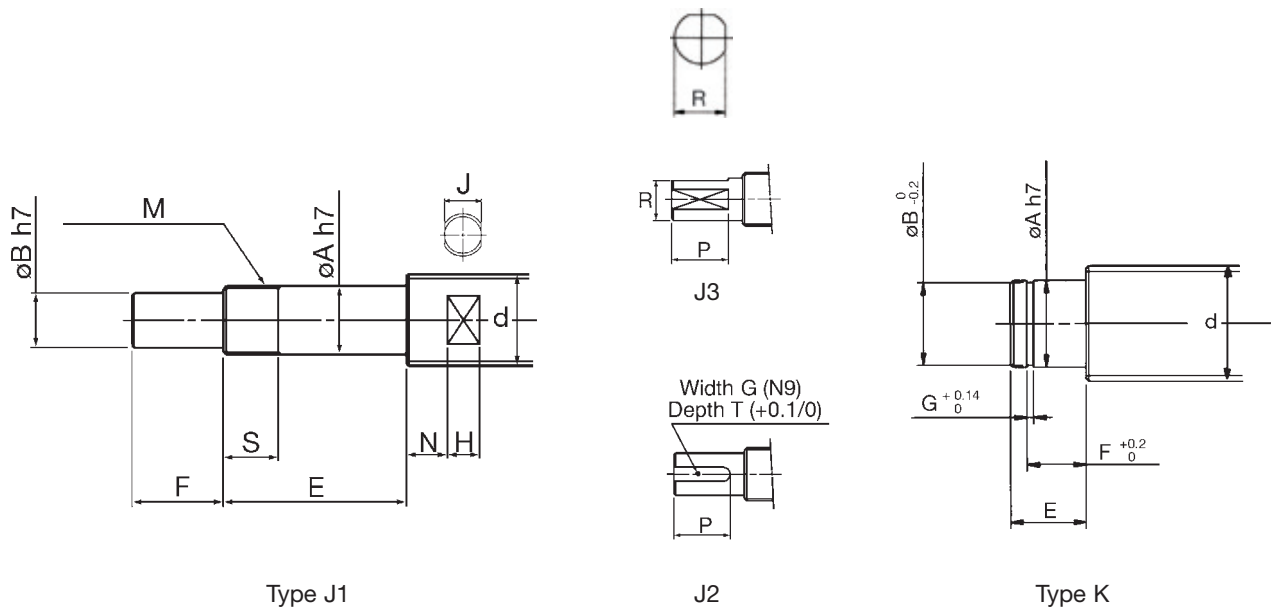

Unit: mm

Shaft diameter d	Fixed BK	Type J						Type J1			Type J2			Type J3			Supported BF	Type K				
		A	B	E	F ¹⁾	M	S	J	N	H	G	T	P	R	P	A		E	B	F	G	
16	BK12	12	10	39	15	M12 × 1	14	13	6	8	3	1.8	12	9.5	12	BF12	10	11	9.6	9.15	1.15	
20	BK15	15	12	40	20	M15 × 1	12	16	6	9	4	2.5	16	11.3	16	BF15	15	13	14.3	10.15	1.15	
25	BK17	17	15	53	23	M17 × 1	17	18	7	10	5	3.0	21	14.3	21	BF17	17	16	16.2	13.15	1.15	
32	BK20	20	17	53	25	M20 × 1	15	27	9	13	5	3.0	21	16	21	BF20	20	16	19.0	13.35	1.35	
40	BK30	30	25	72	38	M30 × 1.5	25	32	10	15	8	4.0	32	23.5	32	BF30	30	21	28.6	17.75	1.75	
50	BK40	40	35	98	50	M40 × 1.5	35	41	14	19	10	5.0	45	33	45	BF40	40	23	38.0	19.95	1.95	

¹⁾ Drive end length F may be customer specified to suit drive coupling. If not specified the length in the table will be used.

Ball Screw Support Units Type FK/FF (Flange Mounting Type)

4 Holes × dia
Counterbored Y dia × Z deep

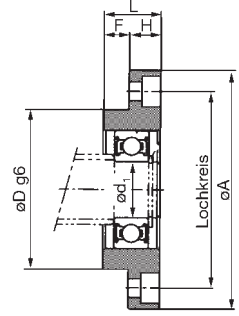
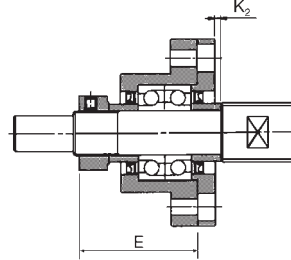
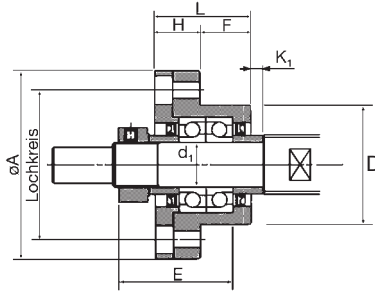
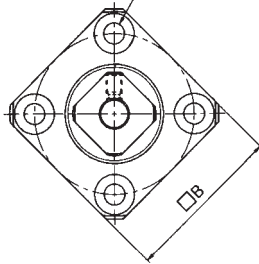

Fixed FK

Supported FF

Unit: mm

Shaft diameter d	Body sizes & Fixing holes Dg6 A PCD B X Y Z							Fixed bearing unit (FK)										Supported bearing unit (FF)							
								FK12	FK15	FK20	FK30	Axial direction					FF12	FF15	FF20	FF30	Radial direction				
d ₁	L	H	F	E	K ₁	K ₂	Dyn. load rat. C ₂ [kN]					Permissible Load [kN]	Rigi- dity [N/μm]	d ₁	L	H					F	Dyn. load rat. C ₂ [kN]	Basic load rating C ₀ [kN]		
16	36	54	44	44	4.5	8	4	FK12	12	27	10	17	29.5	0.5	-0.5	6.66	3.25	88	FF12	10	15	7	8	4.55	1.96
20/25	40	63	50	52	5.5	9.5	6	FK15	15	32	15	17	36	4.0	2.0	7.6	4	100	FF15	15	17	9	8	5.6	2.84
32	57	85	70	68	6.6	11	10	FK20	20	52	22	30	50	1.0	-3.0	17.9	9.5	170	FF20	20	20	11	9	12.8	6.65
40	75	117	95	93	11	17.5	15	FK30	30	62	30	32	61	3.0	-9.0	28	16.3	195	FF30	30	27	18	9	19.5	11.3

Note: For FK units specify H1, H2 or H3 machining. For FF units specify K machining.

Example: **EBB3205 - 4RRGT + 1200LcP5R - H2K¹⁾**

End machining for supported FF 20

End machining for fixed FK 20

¹⁾ End machining for precision ball screw:
Type H2: Fixed bearing unit for FK20
Type K : Supported bearing unit for FF20

End Machining for FK/FF

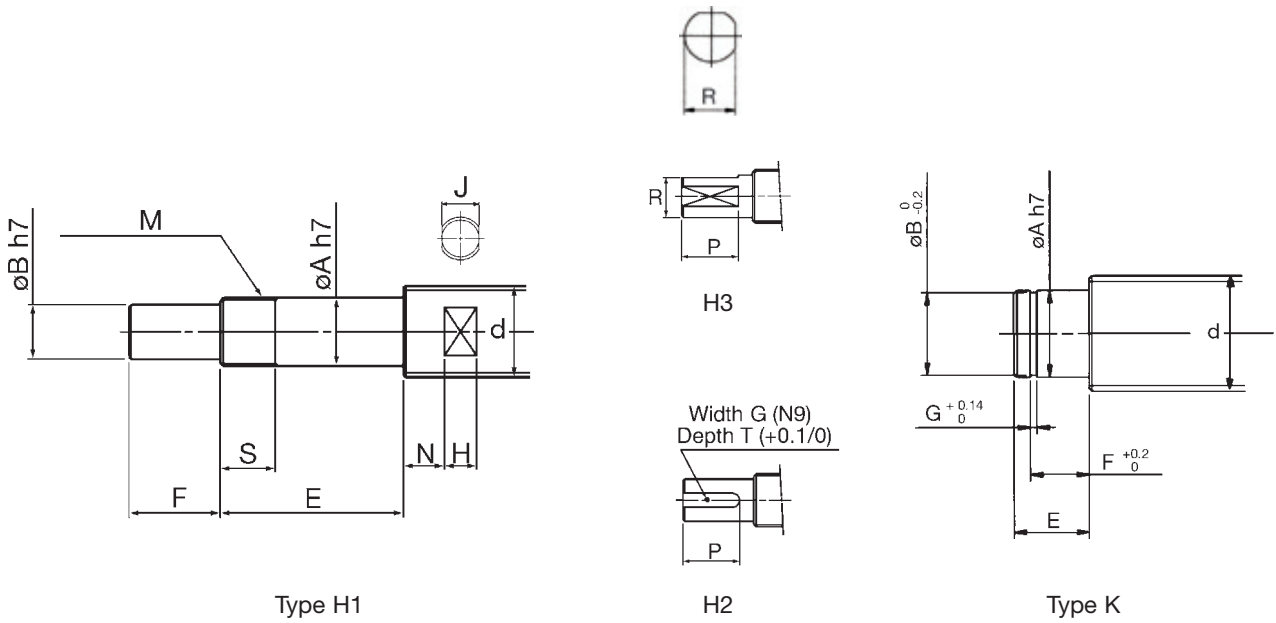

Unit: mm

Shaft diameter d	Fixed FK	Type H						Type H1			Type H2			Type H3			Supported FF	Type K				
		A	B	E	F ¹⁾	M	S	J	N	H	G	T	P	R	P	A		E	B	F	G	
16	FK12	12	10	36	15	M12 × 1	11	13	6	8	3	1.8	12	9.5	12	FF12	10	11	9.6	9.15	1.15	
20	FK15	15	12	49	20	M15 × 1	13	16	6	9	4	2.5	16	11.3	16	FF15	15	13	14.3	10.15	1.15	
25	FK15	15	12	49	20	M15 × 1	13	18	7	10	4	2.5	16	11.3	16	FF15	15	13	14.3	10.15	1.15	
32	FK20	20	17	64	25	M20 × 1	17	27	9	13	5	3.0	21	16	21	FF20	20	19	19.0	15.35	1.35	
40	FK30	30	25	72	38	M30 × 1.5	25	32	10	15	8	4.0	32	23.5	32	FF30	30	21	28.6	17.75	1.75	

¹⁾ Drive end length F may be customer specified to suit drive coupling. If not specified the length in the table will be used.

P5 Ball Screws



Precautions During Use

• Handling

Since the ball screw is a precision component, dropping or subjecting it to strong impacts can result in damage or changes in function. In addition, since the balls will come out if the ball screw nut is disengaged from the screw shaft (ball screw section), please handle with care.

• Assembly

If components are forcibly driven onto the screw shaft or nut, indentations may be formed in the rolling surface. Adequate caution is therefore required so as not to allow excessive force to be applied to the screw shaft and ball screw nut during part assembly.

If the screw shaft support and nut section are off-center or shifted out of position, the service life of the product may be shortened considerably. Adequate caution is therefore required with respect to assembled part accuracy and assembly accuracy.

• Coolant

When this product is used in an environment in which there is the risk of coolant or other similar substance entering the nut section, please consult with THK since product function may be impaired depending on the type of coolant.

• Operating Temperature Range

Since the ball screw uses a special resin, avoid using at temperatures above 80°C.

• Lubrication

Although the ball screw can be used as is since it contains grease (with the exception of special cases), please replenish the grease prior to shipment following trial operation at your firm.

In the case of using in special environments, such as using in locations constantly subjected to the effects of vibrations, or using in a clean room, vacuum or under extremely low or high temperatures, ordinary grease may not be able to be used. In such cases, please inquire to THK.

www.thk.com

Specifications are subject to change without notice

08/2006 Printed in Belgium

Sales Offices

U.K.

THK U.K.
1 Harrison Close
Knowlhill
Milton Keynes
MK5 8PA
Tel. (01908) 303050
Fax. (01908) 303070
info.mks@thk.co.uk

Austria

THK Austria
Edelmüllerstraße 2
4061 Pasching
Tel. (0 72 29) 5 14 00-0
Fax (0 72 29) 5 14 00-79
info.lnz@thk.at

France

THK France S.A.S.
Les Carrés du Parc
10 Rue des Rosiéristes -
Immeuble A
69410 Champagne au
Mont d'or
Tel. (04) 37 49 14 00
Fax (04) 37 49 14 01
info.lys@thk-france.fr

Italy

THK Italy
Via Buonarroti, 182
20052 Monza (MI)
Tel. (0 39) 2 84 20 79
Fax (0 39) 2 84 25 27
info.mil@thk-italia.it

THK Bologna

Via della Salute 16/2
40132 Bologna
Tel. (0 51) 6 41 22 11
Fax (0 51) 6 41 22 30
info.blq@thk-italia.it

Switzerland

Distributor:
Bachofen-AG
Ackerstraße 42
8610 Uster
Tel. (01) 9 44 11 11
Fax (01) 9 44 12 33
www.bachofen.ch
info@bachofen.ch

Germany

THK GmbH
European Headquarters
Düsseldorf Office
Hubert-Wollenberg-Str. 15
40878 Ratingen
Tel. (0 21 02) 74 25-0
Fax (0 21 02) 74 25-29 9
www.thk.de
info.dus@thk.de

Stuttgart Office

Heinrich-Lanz-Str. 3
70825 Kornthal-Münchingen
Tel. (0 71 50) 91 99-0
Fax (0 71 50) 91 99-8 88
info.str@thk.de

Munich Office

Max-Planck-Straße 13
85716 Unterschleißheim
Tel. (0 89) 37 06 16-0
Fax (0 89) 37 06 16-26
info.muc@thk.de

Spain

THK Spain
C/Andorra 19 A
08830 San Boi de Llobregat
Tel. (93) 652 5740
Fax (93) 652 5746
info.bcn@thk.de

Sweden

THK Sweden
Veddestavägen 15B
17562 Järfälla
Tel. (8) 44 57 63 0
Fax (8) 44 57 63 9
info.sto@thk.se

Turkey

THK Istanbul
Merkezi Almanya Türkiye
Istanbul Subesi
Huseyin Celik Sokak
Nail Ergin Is Merkezi No:7
Zemin Kat Daire 2
Kozyatagi-Kadikoy/ Istanbul
Tel. (02 16) 4 63 00 47
Fax (02 16) 4 63 00 42
info.ist@thk.de

USA

THK America, Inc.
THK Chicago
200 East Commerce Drive
Schaumburg, IL. 60173
Tel. (8 47) 3 10-11 11
Fax (8 47) 3 10-12 71
www.thk.com
chicago@thk.com

Canada

THK Canada
130 Matheson Blvd. E., U. 1
Mississauga, Ontario
Canada L4Z 1Y6
Tel. (9 05) 7 12-29 22
Fax (9 05) 7 12-29 25
canada@thk.com

Brasil

THK Brasil Ltda.
Indústria e Comércio Ltda.
Av. Corifeu de Azevedo
Marques, 4077
Butantã - São Paulo - SP
05339-002
Tel. (55-11) 37 67-01 00
Fax (55-11) 37 67-01 01
thk@thk.com.br

China

THK Beijing
Kunlun Hotel
Room No. 417
2 Xin Yuan Lu
Chaoyang District Beijing
Tel. (10) 65 90-32 59
Fax (10) 65 90-35 57

Hong Kong

THK Shouzan Co., Ltd.
4/FI., Hanyee Bldg., Flat C
19-21 Hankow Road
Tsimshatsui, Kowloon
Tel. (8 52) 37 61 09 1
Fax (8 52) 37 60 74 9

Taiwan

THK Taiwan
Suite A, 7FI., No. 152,
Sec 4
Chengde Rd.
Shrlin Chiu, Taipei
Taiwan 112, R.O.C.
Tel. (02) 28 88-38 18
Fax (02) 28 88-38 19

Malaysia

THK Malaysia
B-10-11 Block B (Level 12)
Menara Uncang Emas 85
Jalan Loke Yew
55200 Kuala Lumpur
Tel. (03) 92 87-11 37
Fax (03) 92 87-80 71

India

THK India
1050, 11th Main r.p.c.
Layout Bangalore 560040
Tel. (0 80) 3 30-15 24
Fax (0 80) 3 30-15 24
thk@satyam.net.in

Plants

Europe

THK Manufacturing of Europe, S.A.S.
Parc d' Activités la Passerelle
F-68190 Ensisheim
Tel. (03) 89 83 44 00
Fax (03) 89 83 44 09

PGM Ireland Ltd.

Tallaght Business
Park, Whitetown,
Industrial Estate
Tallaght, Dublin 24
Tel. (01) 4 62-81 01
Fax (01) 4 62-90 80

USA

THK Manufacturing of America, Inc.
471 North High Street
Hebron, OH. 43025
Tel. (7 40) 9 28-14 15
Fax (7 40) 9 28-14 18

China

DALIAN THK CO., LTD.
No.29 Huo Ju Road
Qi xian Ling
Gan Jing Zi District
Dalian City, Liao Ning
Sheng 116023
Tel. (04 11) 84 79 09 99
Fax (04 11) 84 79 01 11

THK MANUFACTURING OF CHINA (WUXI) CO., LTD.
No. 76, WND WUXI,
Jiangsu 214028
Tel. (05 10) 5 34-43 33
Fax (05 10) 5 34-46 66

Korea

Samick LMS CO., LTD.
100-76, Kalsan-Don.
Talseo-ku, Taegu
Tel. (0 53) 5 81-99 31
Fax (0 53) 5 81-82 72

Japan

Head Office:
3-11-6 Nishi-Gotanda
Shinagawa-Ku
Tokyo 141
Tel. (03) 54 34-03 41
Fax (03) 54 34-03 45
www.thk.co.jp
thk001@thk.co.jp

Plants in:

Kofu, Yamaguchi,
Yamagata, Mie, Gifu,
Niigata, Shizuoka,
Miyagi