

RBC Roller® Cam Followers

The Superior Alternative

The Patented Cylindrical Roller Cam Follower
A Clear Winner with New Sizes (1" and 1 1/8") and New Competitive Prices



RBC Division

www.rbcbearings.com
800.390.3300

Patented Cylindrical Roller Cam Followers

RBC invented the RBC Roller® to solve a host of problems associated with old-style needle roller cam followers.

RBC Roller Cam Follower

The Superior Alternative

- RBC Roller cam followers are available in sizes from 1" in roller diameter — an industry exclusive.
- Invented by RBC to solve some of the toughest machine and product control guidance challenges.
- Double row of cylindrical rollers delivers tremendous operating advantages in an economical package.
- Repair and replace cycle is greatly reduced — RBC Roller cam followers operate up to 5 times longer.
- Lubricated for life — No more need for periodic relubrication or expensive automatic lubrication systems.
- Operate at much higher rotary speeds — RBC Roller cam followers operate at speeds up to 2 times higher.
- Increase load carrying capacity without increasing cam follower size — Up to double the dynamic load rating.
- Unique contacting lip seals provide positive protection against contamination while keeping grease inside.
- Specialty configurations (i.e., double outer ring) and corrosion resistance (thin, dense chrome plating) available.

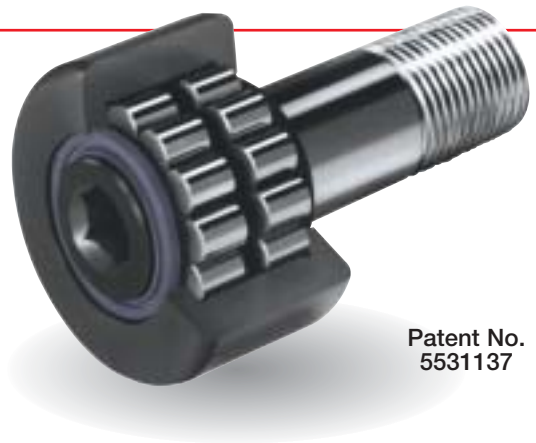

Patent No.
5531137

Needle Roller Cam Follower

Old Generation Technology

- Performance capability limited by old design.
- Must be relubricated to prevent early failure.
- Roller skewing raises operating temperature.
- Needle rollers limit load carrying capacity.
- Gap seals allow intrusion of contamination.
- Inaccurate roller guidance limits operating speed.
- Minimal resistance to thrust loads.



Precisely Guided Cylindrical Rollers

The use of precisely guided rollers dramatically improves all aspects of cylindrical roller cam follower performance. The dynamic load capacity, maximum running speed, and fatigue life are greatly enhanced. See the charts below for specific data regarding these improvements. Lower performance needle roller cam followers rely on rolling elements that have reduced load capacity. They are also subject to more rolling resistance, and generate higher operating temperatures. These unfavorable operating characteristics are the result of comparatively small roller diameter (reduced load capacity) and poor roller guidance, resulting in skewing (excessive frictional heat and reduced fatigue life).

The Best Seals in the Business

Advanced RBC Roller sealing technology provides long-term protection for the rolling element system.

Without effective sealing, even the performance of RBC's precision roller guidance and cylindrical roller technology would be diminished. The contact lip seals provide sealing effectiveness for the cam follower's full operating life. By keeping grease inside the cam follower and contaminants away from the rolling elements, RBC Roller contact lip seals provide a "lubed for life" product.



▲ RBC Roller — latest technology

▲ Needle roller — older technology

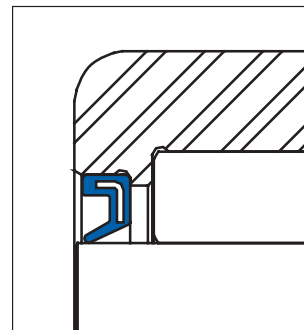

Latest RBC Roller seal design.

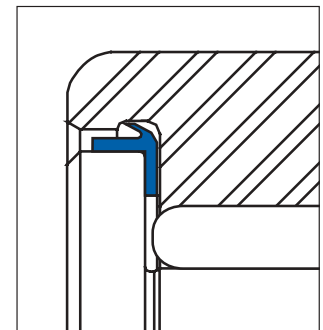

Old-style needle roller cam follower gap seal.

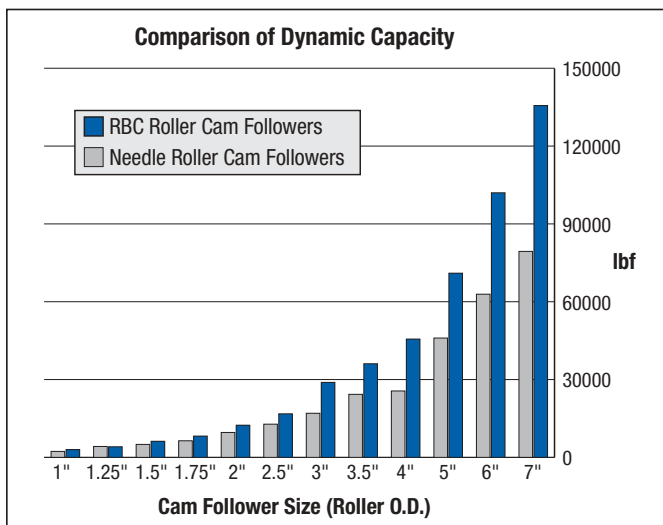

This chart shows the superior load capacity of the RBC Roller cam follower.

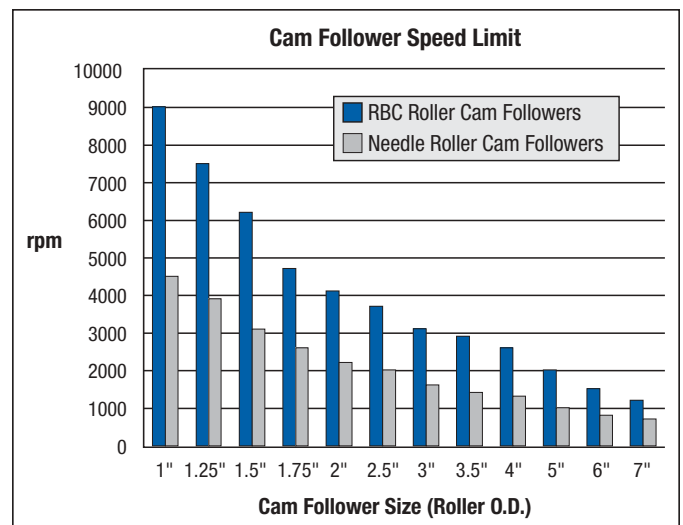

RBC Roller cam followers operate at speeds up to 2 times higher than needle roller cam followers.

The RBC Roller Cam Follower Advantage

RBC Roller Cam Follower

The Latest Design and Technology Innovations

Patented RBC Roller double row cylindrical roller cam followers represent the most effective cam follower technology available. They are superior to needle roller cam followers in every way — lubed for life, higher load capacity, higher speed rating, and longer service life.

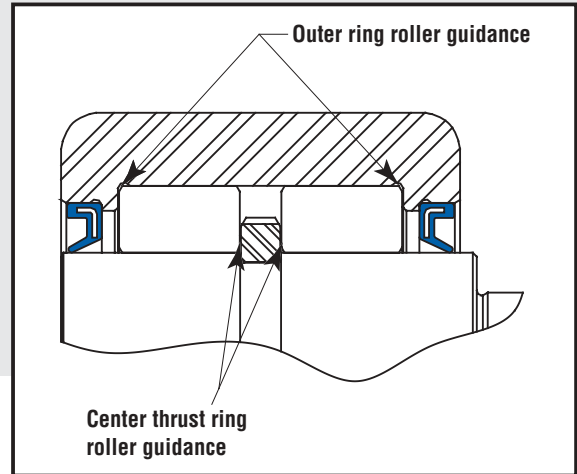

RBC Roller Cam Follower

Contacting Lip Seals

These seals make contact only with the stud ground diameter, therefore maximizing seal life. They are not subject to thrust load against unground surfaces. Their sole function is to provide a secure seal for the retention of lubricant and exclusion of contaminants.

Dual Row Cylindrical Rollers

Large diameter rollers carry high loads. Higher dynamic capacity results in greater fatigue life — greatly prolonging cam follower service life.

Center Thrust Ring

A unique element of the RBC Roller design, the center thrust ring aids in roller guidance and sustains thrust loads generated by cam follower misalignment. Available only in RBC's patented design.

Precise Roller Guidance

RBC Roller cam followers typically run up to 50° F cooler due to accurate roller travel. Cylindrical rollers are guided by both the center thrust ring and internal shoulders of the outer ring.

Large Grease Reservoir

Area between the roller paths is fully charged with up to 4 times more grease than like-sized needle roller cam followers. This additional grease helps to ensure lubed for life performance. Eliminates the need for periodic relubrication.



Needle Roller Cam Follower

Previous Generation Design and Performance

Long, small diameter needle rollers mean lower load capacity, limited speed, and higher operating temperatures. The combination of minimal grease charge volume and more rapid lubricant degradation mean that relubrication is required for even moderate service life.

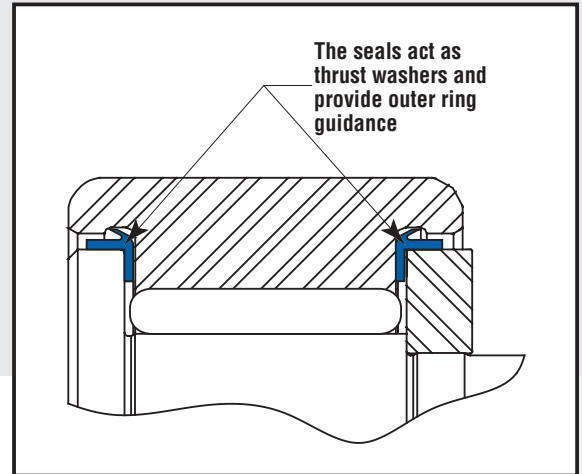

Needle Roller Cam Follower

Gap Seals

These seals are designed to fill the gap between outer ring shoulder and the end ring (see above illustration). This results in substantial frictional and thrust loads on seal surfaces that can lead to rapid wear.

Single Row Needle Rollers

Larger number of small diameter rollers results in lower load rating and reduced fatigue life.



Limited Roller Guidance

End-guided needle rollers tend to skew during normal operation. This can result in excessive heat generation, which can lead to deterioration of the already limited grease supply.

Minimal Grease Retention Volume

The only available area for grease charge is between the rollers. Cam follower life is directly related to effective lubrication. Relubrication of needle roller cam followers is required to maximize life.

RBC Stud Type and Yoke Roller Type Cam Follower Dimensions

RBC Roller — Stud Type

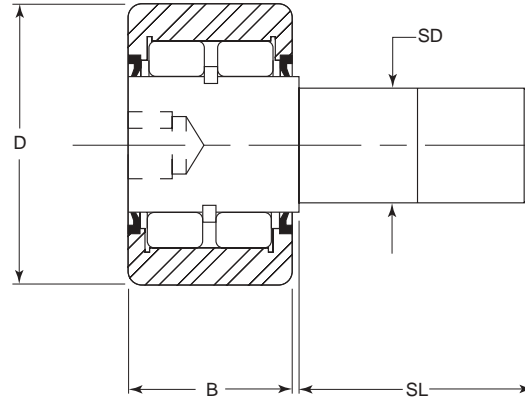

				Stud Type Only		Yoke Type Only		
Part Number	Part Number	D +.000 -.001	B +.000 -.005	SD +.0010 -.0000	SL Stud Length	d Inside Diameter		
						Nom.	Min.	Max.
NEW! RBC 1	RBV 1	1.000	.625	.4375	1.000	5/16	.3121	.3127
NEW! RBC 1 1/8	RBV 1 1/8	1.125	.625	.4375	1.000	5/16	.3121	.3127
RBC 1 1/4	RBV 1 1/4	1.250	.750	.5000	1.250	3/8	.3746	.3752
RBC 1 3/8	RBV 1 3/8	1.375	.750	.5000	1.250	3/8	.3746	.3752
RBC 1 1/2	RBV 1 1/2	1.500	.875	.6250	1.500	7/16	.4371	.4377
RBC 1 5/8	RBV 1 5/8	1.625	.875	.6250	1.500	7/16	.4371	.4377
RBC 1 3/4	RBV 1 3/4	1.750	1.000	.7500	1.750	1/2	.4996	.5002
RBC 1 7/8	RBV 1 7/8	1.875	1.000	.7500	1.750	1/2	.4996	.5002
RBC 2	RBV 2	2.000	1.250	.8750	2.000	5/8	.6246	.6252
RBC 2 1/4	RBV 2 1/4	2.250	1.250	.8750	2.000	5/8	.6246	.6252
RBC 2 1/2	RBV 2 1/2	2.500	1.500	1.0000	2.250	3/4	.7496	.7502
RBC 2 3/4	RBV 2 3/4	2.750	1.500	1.0000	2.250	3/4	.7496	.7502
RBC 3	RBV 3	3.000	1.750	1.2500	2.500	1	.9995	1.0001
RBC 3 1/4	RBV 3 1/4	3.250	1.750	1.2500	2.500	1	.9995	1.0001
RBC 3 1/2	RBV 3 1/2	3.500	2.000	1.3750	2.750	1 1/8	1.1245	1.1251
RBC 4	RBV 4	4.000	2.250	1.5000	3.500	1 1/4	1.2495	1.2501
RBC 5	RBV 5	5.000	2.750	2.0000	5.062	1 3/4	1.7495	1.7501
RBC 6	RBV 6	6.000	3.250	2.5000	6.000	2 1/4	2.2495	2.2501
RBC 7	RBV 7	7.000	3.750	3.0000	7.688	2 3/4	2.7495	2.7501
RBC 8	RBV 8	8.000	4.250	3.2500	8.500	3 1/4	3.2550	3.2560
RBC 9	RBV 9	9.000	4.750	3.7500	9.500	3 3/4	3.7550	3.7560
RBC 10	RBV 10	10.000	5.250	4.2500	10.000	4 1/4	4.2550	4.2560

NEW! 1" and 1 1/8" are new, industry-exclusive sizes.

All sizes are available in crowned and oil hole versions.

and Performance Data

RBC Roller — Yoke Type

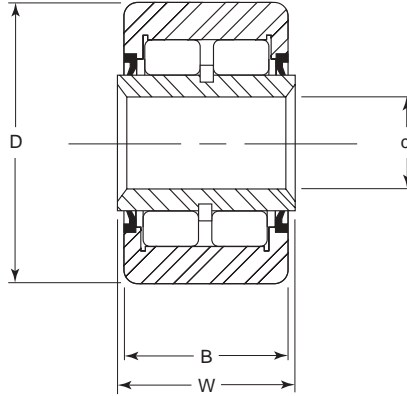

W Overall Width +.0050 -.0100	Speed Limit (rpm)	C Bearing Dynamic Capacity (lbf)
.6925	9,400	3,000
.6925	9,400	3,000
.8125	7,500	4,100
.8125	7,500	4,100
.9375	6,200	6,200
.9375	6,200	6,200
1.0625	4,700	8,200
1.0625	4,700	8,200
1.3125	4,100	12,400
1.3125	4,100	12,400
1.5625	3,700	16,800
1.5625	3,700	16,800
1.8125	3,100	28,900
1.8125	3,100	28,900
2.0625	2,900	36,100
2.3125	2,600	45,600
2.8750	2,000	71,000
3.3750	1,500	102,000
3.8750	1,200	135,600
4.5000	1,100	175,400
5.0000	1,000	221,000
5.5000	900	272,000

Needle Roller Cam Followers				
Nominal Size	Interchange Part Number		Speed Limit (rpm)	C Bearing Dynamic Capacity (lbf)
1	S 32	CF-1	4,500	2,300
1 1/8	S 36	CF-1 1/8	4,500	2,300
1 1/4	S 40	CF-1 1/4	3,900	4,200
1 3/8	S 44	CF-1 3/8	3,900	4,200
1 1/2	S 48	CF-1 1/2	3,100	5,000
1 5/8	S 52	CF-1 5/8	3,100	5,000
1 3/4	S 56	CF-1 3/4	2,600	6,400
1 7/8	S 60	CF-1 7/8	2,600	6,400
2	S 64	CF-2	2,200	9,600
2 1/4	S 72	CF-2 1/4	2,200	9,600
2 1/2	S 80	CF-2 1/2	2,000	12,800
2 3/4	S 88	CF-2 3/4	2,000	12,800
3	S 96	CF-3	1,600	17,000
3 1/4	S 104	CF-3 1/4	1,600	17,000
3 1/2	S 112	CF-3 1/2	1,400	24,300
4	S 128	CF-4	1,300	30,000
5	S 160	CF-5	1,000	47,200
6	S 192	CF-6	800	62,900
7	S 224	CF-7	700	79,400



Innovation. Commitment. Quality.

RBC has been producing bearings in the USA since 1919. In addition to unique custom bearings, RBC offers a full line of standard industrial and aerospace bearings, including:



Spherical Plain Bearings

Radial, angular contact, extended inner ring, high misalignment. **QuadLube**®, **ImpactTuff**®, **ShimPack**®, **CrossLube**®, bearings, and self-lubricating bearings. Available in inch and metric sizes.



Rod Ends

Commercial and industrial, precision, Mil-Spec series, self-lubricating, and aircraft. **Heim Unibal**® and **Spherco**® brands. Available in inch and metric sizes.



Thin Section Ball Bearings

Standard cross sections to one inch. Sizes to 40 inches. Stainless steel and other materials are available. Seals are available on all sizes and standard cross sections.



Ball Bearings

Precision ground, semiground, unground. High loads, long life, smooth operation. **Nice**® brand is offered in caged and full complement configurations.



Self-Lubricating Bearings

Radial, thrust, rod ends, spherical bearings, high temperature, high loads. Available in inch and metric sizes. **Fiberglide**®.



Cam Followers

Standard stud, heavy stud, yoke type, caged roller followers. Patented **RBC Roller**® cylindrical roller cam followers, **HexLube**® universal cam followers,



Airframe Control Bearings

Ball bearing types, self-lubricating types, needle roller track rollers.



Needle Roller Bearings

Pitchlign® caged heavy duty needle roller bearings, inner rings, **TJ TandemRoller**® bearings for long life.



Pins and Shafts

Bremen and **Miller** pins, needle rollers, shafts, and rollers.



Tapered Roller Bearings

Tyson® brand case-hardened in many sizes. Used in Class 8 heavy truck and trailer wheel bearings, gearboxes, and final drive transmissions.



Ball Screws

Precision ground, rolled, ball splines. Long life, low wear, high accuracy. **QuickTurn™ Ball Screw Repair Service**.



Specials

RBC manufactures many specialty bearings for the aerospace, oil and energy, semiconductor equipment, packaging, heavy truck, and other